



## PRELIMINARY

# C-BOX Profibus DP

## *Connection Box with Profibus DP converter*

### FEATURES

- Electrically isolated RS485 Profibus DP interface (host side)
- Profibus ASIC based on Siemens SPC3 chip technology
- Baudrate up to 12 Mbs
- Easiness and flexibility in the cabling operation
- Possible connection of a Hand Held Reader
- GET/STORE/SEND of the configuration of the connected scanner.
- Display version available

### GENERAL DESCRIPTION

In many modern industrial environments it is becoming increasingly more common for peripheral data collection devices (photocells, proximity sensors, fixed scanners, handheld readers, electric valves, other kinds of sensors etc.) to have a direct connection to Profibus DP. The **C-BOX Profibus DP** is the ideal solution for all the applications that use this kind of plants, especially in the Manufacturing but also in the Transportation & Logistic and Distribution industries. The **C-BOX Profibus DP** makes it possible to connect to a Profibus DP master, a single scanner or a cluster made of a few scanners connected in either master/slave or pass through (RS232). The **C-BOX Profibus DP** can be connected via the RS232 interface to the decoded scanners of the 1000, 2000, 4000 series and the DX8200 as well as to a Datalogic Hand Held Reader (Gryphon™ or Dragon™). All the Profibus DP parameters can be adjusted through Winhost™. Moreover there are rotating switches to select the Profibus DP slave address. An additional user layer developed by Datalogic make it possible to increase the communication reliability by fragmenting long messages and adding a flow control protocol.

Besides the Profibus DP gateway function, the **C-BOX Profibus DP** has 32 internal stud spring terminal block and 5 external cable glands for easy cabling operations. In addition, the **C-BOX Profibus DP** offers important benefits to reduce the system downtime such as the possibility to GET, STORE and SEND the configuration of the connected scanner and the external auxiliary service interface.

The **C-BOX Profibus DP** is available in two models, the **C-BOX 300** as the entry level, and the **C-BOX 310** that offers additional features such as an external display and keyboard, the possibility to force the scanner in test mode and the local echo of the read barcode.

## MODELS

PRODUCT	DESCRIPTION	ORDER NO.
C-BOX 300	Profibus DP Connection Box	93A301000
C-BOX 310	Profibus DP Connection Box with Display	93A301030

## SPECIFICATIONS

POWER SUPPLY	10 to 30 VDC	DIMENSIONS	see drawing
POWER CONSUMPTION	C-BOX 300 max. 6W C-BOX 310 max. 6.5W	WEIGHT	C-BOX 300 about 600 g C-BOX 310 about 750 g
<b>PROFIBUS DP</b>		OPERATING TEMPERATURE	0 to 40 °C
BAUD RATE	Up to 12 Mbit/s	STORAGE TEMPERATURE	-20 to 70 °C
EXCHANGE MEMORY FOR I/O DATA	Up to 32 byte	HUMIDITY	90% non condensing
<b>RS232</b>		VIBRATION RESISTANCE	IEC 68-2-6 Test FC 1.5 mm; 10 to 55 Hz; 2 hours on each axis IEC 68-2-27 Test EA 30 G; 11 ms; 3 shocks on each axis
BAUD RATE	Up to 115.2 Kbit/s	SHOCK RESISTANCE	

## DIMENSIONS

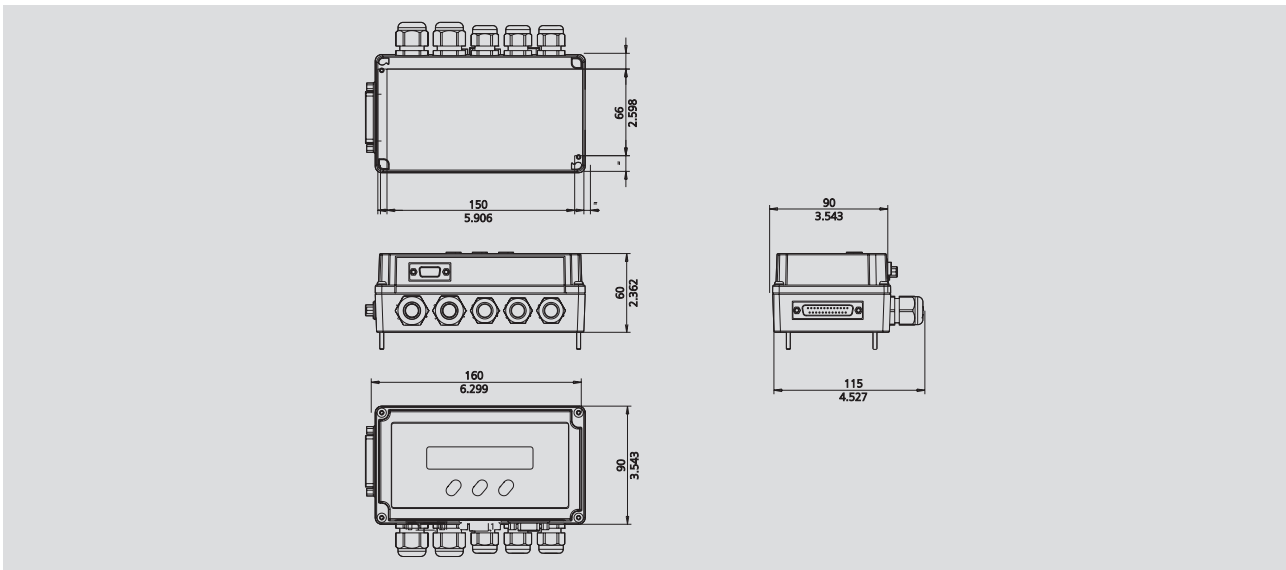

Product and company names and logos referenced may be either trademarks or registered trademarks of their respective companies.

We reserve the right to make modifications and improvements

**Datalogic S.p.A.**  
Italy  
Corporate Headquarters  
Tel. +39 051/3147011  
Fax +39 051/726562  
info@datalogic.it

**Sales Italy**  
Tel. +39 051/3147300  
Fax +39 051/726562  
venditeitalia@datalogic.it

**Sales International**  
(Central and South America,  
Far East, Middle East - Africa)  
Tel. +39 041/5986511  
Fax +39 041/5986550  
sales-intl@datalogic.it

**Australia**  
Datalogic PTY LTD.  
Tel. +61 3/95589299  
Fax +61 3/95589233  
sales@datalogic.com.au  
info@datalogic.de

**Germany**  
Datalogic GmbH  
Tel. +49 7026/6080  
Fax +49 7026/5746  
info@datalogic.de

**Sweden**  
Datalogic AB  
Tel. +46 40/385000  
Fax +46 40/385001  
info@datalogic.se

**Austria**  
Datalogic Handelges MBH  
Tel. +43 2236/258820  
Fax +43 2236/258825  
office@datalogic.co.at

**Japan**  
Izumi Datalogic Co., Ltd.  
Tel. +81 78/3033400  
Fax +81 78/3033402  
idlmarke@izumi-datalogic.co.jp

**United Kingdom**  
Datalogic UK Ltd.  
Tel. +44 1582/464900  
Fax +44 1582/464999  
enquiries@datalogic.demon.co.uk

**Denmark**  
Datalogic AB  
Tel. +45 44/209970  
Fax +45 44/209972  
info@datalogic.se

**Netherlands**  
Datalogic Optic Electronics BV  
Tel. +31 346/572888  
Fax +31 346/568736  
info@datalogic.nl

**U.S.A.**  
Datalogic Inc.  
Tel. +1 859/6897000  
Fax +1 859/3344970  
info@datalogic.com

**France**  
Datalogic France S.A.  
Tel. +33 1/60921111  
Fax +33 1/60921340  
dlfrance@datalogic.it

**Spain**  
Datalogic Iberia  
Tel. +34 91/3837755  
Fax +34 91/3837962  
dliberia@datalogic.it

### Datalogic Quality Partner

H+P Betriebsdatenlogistik GmbH  
Am Weichselgarten 6  
91058 Erlangen  
Germany

Tel.: 09131-75740  
Fax: 09131-757474  
Email: info@h-pgmbh.de  
Internet: www.h-pgmbh.de